

[54] CAFLY

[76] Inventor: Ferdinand Ferino, 193 Cottoman Ave., Philadelphia, Pa. 19111

[22] Filed: Mar. 5, 1971

[21] Appl. No.: 121,466

[52] U.S. Cl.....180/1 FV, 180/25, 280/7.1, 280/43.23, 280/78, 296/1 S

[51] Int. Cl.....B62d 35/00, B62d 37/02

[58] Field of Search .....180/26, 25, 1 FV; 296/1 S; 280/7.1

FOREIGN PATENTS OR APPLICATIONS

885,818 6/1953 Germany.....296/1 S

Primary Examiner—Benjamin Hersh  
Assistant Examiner—John P. Silverstrim  
Attorney—Woodcock, Washburn, Kurtz & Mackiewicz

[57] ABSTRACT

A vehicle for traveling upon the ground, the vehicle including a pair of front wheels mounted in tandem side by side arrangement and a singular rear wheel, a pair of wings above the body and a fin rudder, the vehicle normally travelling at lower speed with all three wheels engaging the ground, the vehicle after attaining a 40 mile per hour speed then travelling upon only the rear wheel engaging the ground while the front wheels retract upwardly, balance being provided to the vehicle by means of the wings, together with the fin rudder.

4 Claims, 5 Drawing Figures

[56] References Cited

UNITED STATES PATENTS

D137,312	2/1944	Wood.....	296/1 S X
1,777,781	10/1930	Biagi.....	280/263 X
3,610,660	10/1971	Price.....	280/289
1,986,845	1/1935	Napier.....	296/1 S
3,512,825	6/1968	Green.....	296/1 S
2,434,759	1/1948	Donovan.....	180/25 R X

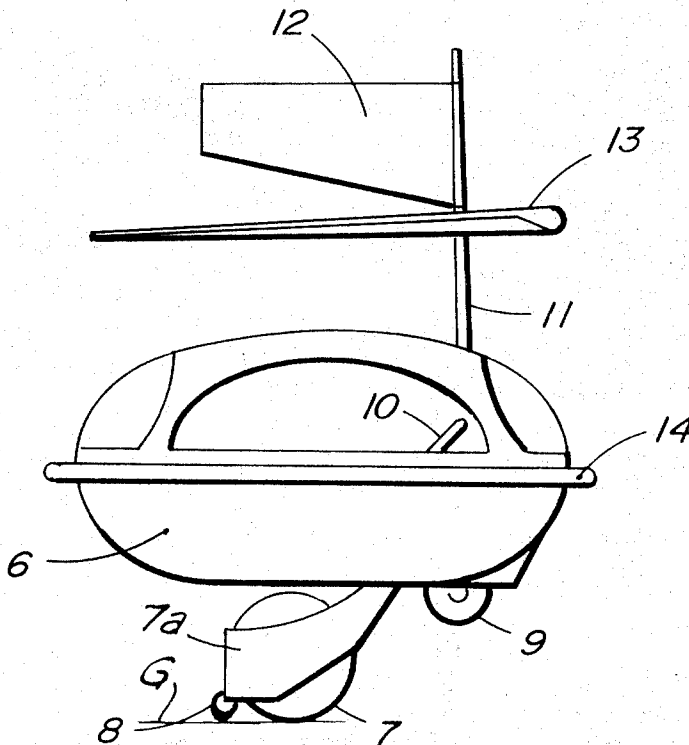

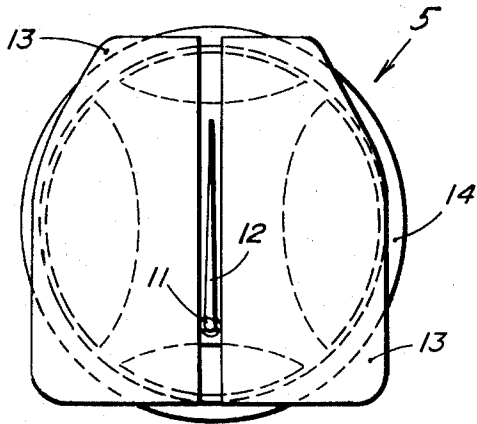

Fig. 1

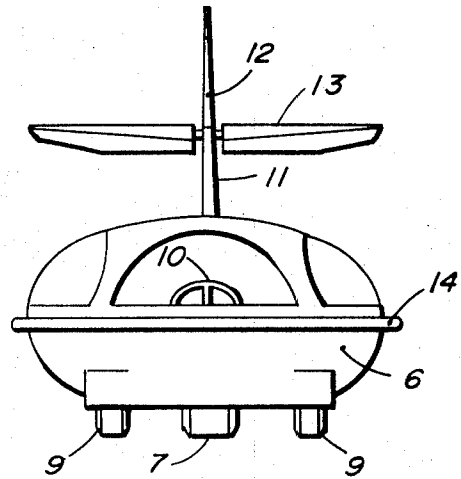

Fig. 2

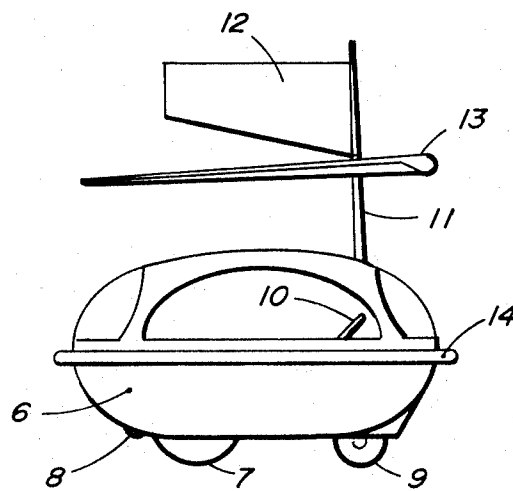

Fig. 3

INVENTOR.  
**Ferdinand Ferino**

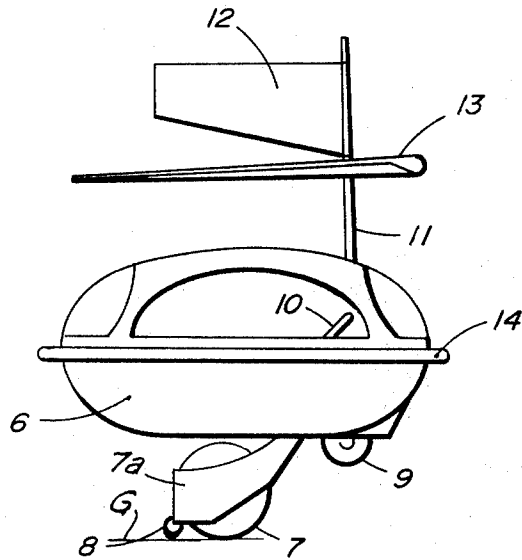

Fig. 4

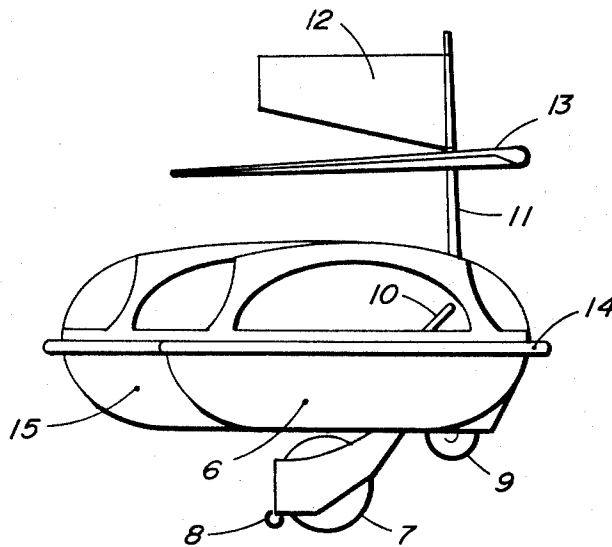

Fig. 5

INVENTOR.

Ferdinand Ferino

## CAFLY

This invention relates generally to land-going vehicles.

A principal object of the present invention is to provide a novel land-going vehicle which at low speed travels upon several wheels engaging the ground, but wherein after a relatively large speed is attained, the vehicle travels with only one wheel engaging the ground while the other wheels retract upwardly into the body.

Another object of the present invention is to provide a cafly wherein the vehicle further includes a pair of wing which aid in balancing the vehicle while traveling upon one wheel engaging the ground.

Still another object of the present invention is to provide a cafly which additionally includes a fin rudder for assisting in controlling steering by utilizing the movement of the vehicle through the air.

Other objects of the present invention are to provide a cafly which is simple in design, inexpensive to manufacture, rugged in construction, easy to use and efficient in operation.

These and other objects will be readily evident upon a study of the following specification and the accompanying drawing wherein:

FIG. 1 is a top plan view of the present invention,

FIG. 2 is a front elevation view thereof showing the three wheels on the ground,

FIG. 3 is a left side elevation view thereof shown on the ground,

FIG. 4 is a left side elevation view showing the device after attaining a 40 mile speed with only one wheel engaging the ground, and

FIG. 5 is a left side elevation view of the invention shown with an extension for two additional passengers.

Referring now to the drawings in detail, the reference numeral 5 represents a cafly according to the present invention wherein there is a body 6 of generally fusilage configuration so to be streamlined for moving relatively friction free while passing through the air.

A rear motor wheel 7 is centrally positioned beneath a rear of the body 6 which is mounted rotatably free within a downwardly pivotable bracket 7A, a rear lower edge of the pivotable bracket 7A being provided with a balance wheel 8 which engages a ground G when the wheel 7 alone engages the ground as shown in FIG. 4 of the drawing.

Below a forward portion of the body 6, there is a pair of front wheels 9 which are in axial alignment with each other, the wheels 9 being of relatively smaller diameter than the rear motor 7; the rear wheel being powered by a motor contained within the vehicle.

Within the vehicle there is a steering wheel 10 and the body is provided with a front windshield, side windows and a rear window, it being understood that the right side of the vehicle not shown, includes an access door for entry into the vehicle for persons.

Alternately other access means may be provided such as an upwardly pivotable dome or the equivalent, such as is known in vehicle art.

An upwardly extending control mast 11 protrudes from the top of the body, the upper end of the control mast supporting a thin rudder 12.

Adjacent each side of the control mast 11 there is a wing 13 that comprises an aileron which is pivotable about a transverse axis extending through the control

mast and which is controlled by mechanisms from within the interior of the vehicle by a driver.

A bumper 14 is located all around the sides of the body so as to prevent shock and damage to the craft in case of being bumped.

In FIG. 5 of the drawings, there is shown a modified design of the invention which is adaptable to include an extension for accommodating two additional passengers within the interior of the vehicle.

In operative use, it is now evident there has been provided a cafly vehicle for traveling upon the ground or highway and which when travelling at relatively lower speeds travels with all three wheels contacting the ground, such as is shown in FIGS. 2 and 3 of the drawing.

After the vehicle attains a speed of forty miles per hour, the rear wheel bracket 7A is pivotally lowered so as to raise the body together with its front wheels upwardly into the air while the rear wheel 7 maintains contact with the ground G.

The wheel 7 is powered by a motor in the vehicle so as to permit the craft to move.

In this position, a balance wheel 8 at the rear of the wheel 7 assists in maintaining balance of the craft.

Sidewardly balance to the vehicle is provided by means of wing ailerons 13 as well as the fin rudder, both of which thus utilize the air for accomplishing the balance and steering the vehicle.

It is now evident furthermore, that such vehicle by maintaining a minimum contact with the ground is able to develop greater speed than are possible with a conventional automotive vehicle with many wheels engaging the ground.

Thus there is provided a novel vehicle that should give an additional thrill to automotive enthusiasts by giving a new type of ride.

What I now claim is:

1. A land vehicle comprising:

a body;  
a pair of front wheels in axial alignment with each other and rotatably mounted with respect to said body;  
a bracket for mounting said rear wheel;  
means for pivotably lowering said bracket from within said body causing said body and said front wheels to raise;  
a power plant mounted with respect to said body; and  
air foil means for utilizing movement of the vehicle to balance said vehicle, said power plant producing sufficient power to enable said vehicle to attain a specified speed at which time said rear wheel bracket may be pivotally lowered causing said body and said front wheels to raise whereby said vehicle will travel solely on its rear wheel while being balanced and controlled by said air foil means.

2. The land vehicle of claim 1 wherein said rear wheel is relatively larger than said pair of front wheels.

3. The land vehicle of claim 1, wherein said airfoil means comprises an upstanding control mast upon the top of said body, said control mast at its upper end being provided with a fin rudder, an intermediate portion of said control mast supporting a wing aileron upon each side thereof which are pivotable about a transverse axis extending through said control mast.

**3**

**4**

4. The combination as set forth in claim 3, wherein said body of said vehicle is of fusilage configuration by being streamlined, said body includ a front windshield, rear window, opposite side windows and an access opening for entry and exit of passengers, said body additionally being provided with a bumper all around the same.

\* \* \* \* \*

10

15

20

25

30

35

40

45

50

55

60

65

UNITED STATES PATENT OFFICE  
CERTIFICATE OF CORRECTION

Patent No. 3,724,577

Dated April 3, 1973

Inventor(s) Ferdinand Ferino

It is certified that error appears in the above-identified patent and that said Letters Patent are hereby corrected as shown below:

On the first page of the patent, change the address of the inventor from "193 Cottoman Ave." to -- 1930 Cottman Ave. --.

On the first page of the patent, the firm name should read -- Woodcock, Washburn, Kurtz & Mackiewicz --.

Column 1, line 13, after "wing" insert -- ailerons --.

Signed and sealed this 27th day of November 1973.

(SEAL)

Attest:

EDWARD M. FLETCHER, JR.  
Attesting Officer

RENE D. TEGTMAYER  
Acting Commissioner of Patents